

Southern Indiana Stormwater Best Management Practices (BMPs) Stormwater Pollution Prevention (SPPs)		SPP-01										
Activity: Permanent, Grass, Vines and Other Vegetation												
PLANNING CONSIDERATIONS: Design Life: Life Acreage Needed: As Needed Estimated Unit Cost: Variable Monthly Maintenance: Negligible												
		Target Pollutants										
		Significant ♦ Partial ♦ Low or Unknown ♦										
<table border="0" style="width: 100%; text-align: center;"> <tr> <td>Sediment ♦</td> <td>Heavy Metals ♦</td> <td>Nutrients ♦</td> <td>Oxygen Demanding Substances ♦</td> <td>Toxic Materials ♦</td> </tr> <tr> <td>Oil & Grease ♦</td> <td>Bacteria & Viruses ♦</td> <td>Floatable Materials ♦</td> <td>Construction Waste ♦</td> <td></td> </tr> </table>			Sediment ♦	Heavy Metals ♦	Nutrients ♦	Oxygen Demanding Substances ♦	Toxic Materials ♦	Oil & Grease ♦	Bacteria & Viruses ♦	Floatable Materials ♦	Construction Waste ♦	
Sediment ♦	Heavy Metals ♦	Nutrients ♦	Oxygen Demanding Substances ♦	Toxic Materials ♦								
Oil & Grease ♦	Bacteria & Viruses ♦	Floatable Materials ♦	Construction Waste ♦									
Description	<p>The long term stabilization of soil occurs as a result of ground cover provided by seeding of grasses and planting of trees, shrubs and vines. The long-term aesthetics reduces erosion by slowing runoff velocities, enhance infiltration and transpiration, trap sediment and other particulates, protect soil from raindrop impact, and provide habitat for wildlife.</p>											
Suitable Applications	<p>This BMP is suitable for:</p> <ul style="list-style-type: none"> Site stabilization both during construction and post-construction. Any graded/cleared areas where construction activities are completed. Open space cut and fill areas. Steep slopes not requiring more robust permanent stabilization techniques. Spoil or stock piles. Vegetated swales and ditches. Landscape corridors. Areas of stream banks with low velocities under storm conditions. 											
Installation Procedures	<p>These systems should be designed by a licensed professional civil engineer. Many of the measures presented in EPP-05: Temporary Seeding, EPP-09: Nets and Mats, and EPP-10: Geotextiles are applicable for establishing, stabilizing and maintaining permanent vegetation.</p> <p>Application of appropriate vegetation must consider: the seedbed or plant bed, proper seasonal planting times, water requirements, fertilizer requirements and availability of the selected vegetation within the project's region.</p> <p>Type of vegetation, site and seedbed preparation, planting time, fertilization and water requirements should be considered for each application.</p>											

Installation Procedures (Continued)

Seeding and planting should be applied as soon as final grading is done to all graded and cleared areas of the construction site where plant cover is ultimately desired. For example, vegetation may be established along landscaped corridors and buffer zones where they may act as filter strips.

Vegetated swales, steep and/or rocky slopes and stream banks can also serve as appropriate areas for seeding and plantings.

Permanent plantings during the construction stage of projects require careful coordination between the local agency inspectors, project managers, construction managers, and landscape contractor. Protocols for coordination and implementation procedures regarding site access, construction staging, and short- and long-term planting areas should be developed prior to the construction bid process. Where possible, these protocols should be established by and remain the responsibility of the site owner.

Grasses

Grasses, depending on the type, provide short-term soil stabilization during construction or can serve as long-term/ permanent soil stabilization for disturbed areas. In general, grasses provide low maintenance to areas that have been cleared, graded and mechanically stabilized.

They are generally tolerant of short-term temperature extremes and waterlogged soil conditions.

Appropriate soil conditions for unreinforced grasses: shallow soil base, good drainage, slope 2:1 (H: V) or flatter.

Develop well and quickly from seeds.

Mowing, irrigating, and fertilizing are vital for promoting vigorous grass growth.

Selection:

The selection of the grass type is determined by the climate, irrigation, mowing frequency, maintenance effort and soil bed conditions. Although grasses provide quick germination and rapid growth, they also have a shallow root system and are not as effective in stabilizing deep soils, where trees, shrubs and deep rooted ground covers may be more appropriate. Bluegrass is good on dry, sandy soils that have good drainage. Bermuda grass, on the other hand is well adapted to regions where soils are dry, coarse and heavier. Specific seed mix and/or varieties for each site should be provided by an approved/qualified plant materials specialist.

Installation Procedures (Continued)

Planting:

The following steps should be followed to ensure established growth:

1. Select the proper grass for the site.
2. Prepare the seedbed; soil should be fertilized and contain good topsoil or soil at a 2:1 (H: V) or flatter slope, unless stabilized with permanent geotextiles, nets or mats.
3. Broadcast the seedings in the late fall or early spring.
4. Initial irrigation will be required often for most grasses, with follow-up irrigation and fertilization as needed. Light mulching may be required during drought years or to limit seed lost to wind and birds.

Trees and Shrubs

Soil conditions: select species appropriate for soil, drainage & acidity.

Other Factors: wind/exposure, temperature extremes, and irrigation needs.

Selection:

Trees and shrubs, when properly selected, are low maintenance plantings that stabilize adjacent soils, moderate the adjacent temperatures, filter air pollutants, and serve as a barrier to wind. Some desirable characteristics to consider in selecting trees and shrubs include: vigor, species, age, size and shape, and use as a wildlife food source and habitat.

Transplanting:

Time of Year – Late fall through winter (November to February) is the preferred time for transplanting.

Preparation – Proper digging of a tree/shrub includes the conservation of as much of the root system as possible. Soil adhering to the roots should be damp when the tree is dug, and kept moist until re-planting. The soil ball should be 12 inches in diameter for each inch of diameter of the trunk.

Site preparation – Refer to landscape plans and specifications for site and soil preparation, and for ability to coordinate construction strategy with permanent vegetation.

Supporting the trunk – Many newly planted trees/shrubs need artificial support to prevent excessive swaying.

Watering – Soil around the tree should be thoroughly watered after the tree is set in place. When the soil becomes dry, the tree should be watered deeply, but not often. Mulching around the base of the tree is helpful in preventing roots from drying out.

Vines and Ground Covers

Ground preparation: lime and fertilizer preparation.

Appropriate soil conditions: drainage, acidity, slopes.

Generally avoid invasive species (Kudzu, etc.).

Activity: Permanent, Grass, Vines and Other Vegetation

SPP-01

Installation Procedures (Continued)

Generally avoid species requiring frequent irrigation.

Selection:

Vines, ground covers, and low growing plants, that can quickly spread, come in many types, colors, and growth habits. Some are suitable only as part of a small maintained landscape area, while some can stabilize large areas with little maintenance. Flowers, which provide little long-term erosion control, may be planted to add color and veritable appearances.

Site Preparation:

Ground covers are plants that naturally grow very close together, causing severe competition for space, nutrients and water. Soil for ground covers should be well prepared. The entire area should be spaded, disked, or roto-tilled to a depth of six to eight inches. Two to three inches of organic material, such as good topsoil or peat, should be spread over the entire area.

Planting:

The following steps will help ensure good plant growth.

1. Position the plantings to follow the contours of the land.
2. Dig the holes 1/3 larger than the plant root ball.
3. Know what depth to place the plants.
4. Use good topsoil or soil mixture with a lot of organic matter.
5. Fill hole to 1/2 full, shake plants to settle soil among roots, then water.
6. Leave saucer-shaped depression around the plant to hold water.
7. Water thoroughly and regularly.
8. Space plants according to the type of plant and the extent of covering desired.

Materials:

There are many different species of vines and ground covers from which to choose, but care must be taken in their selection. It is essential to select planting materials suited to both the intended use and specific site characteristics. Additional information can be obtained from local nurserymen, landscape architects, and extension agents.

Maintenance

Grass maintenance should be minimal to none. Irrigation and regular fertilizing may be required for some types of grasses. Mowing is only required in areas where aesthetics or fire hazards are a concern.

Permanent vegetation may require supplemental irrigation where the natural rainfall is insufficient to establish and/or maintain the selected plant materials. Selecting native plants should be considered where supplemental irrigation is not available. However, even native plants benefit from supplemental irrigation during the establishment period.

Young trees should receive an **inch of water each week for the first two years** after planting. The tree should be watered deeply, but not more often than once per week.

Transplanted trees should be fertilized on an annual basis.



Proper pruning, watering, and application of fertilizer are necessary to maintain healthy and vigorous shrubs. A heavy layer of mulch applied around the shrubs reduces weeds and retains moisture.

Trim old growth as needed to improve the appearance of ground covers. Most covers need once-a-year trimming to promote growth.

See GHP-15: Pesticides, Herbicides and Fertilizer Use.

Inspection Checklist

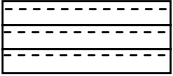
- ☐ If the site is susceptible to erosion, additional control measures may be necessary during the establishment of vegetation.
- ☐ Caution should be exercised in introducing non-native vegetation because of impacts to native vegetation on adjacent lands. For example, species that may be planted at the construction site can quickly spread and compete with originally undisturbed vegetation.
- ☐ Permanent and temporary vegetation establishment may not be appropriate during dry periods without irrigation.
- ☐ Over-application of fertilizers, herbicides and pesticides may create stormwater pollution.
- ☐ Construction activities are likely to injure or kill trees unless adequate protective measures are taken. Direct contact by equipment is the most obvious problem, but damage is also caused by root stress from filling, excavation, or compacting soil too close to trees.
- ☐ Temporary seeding can only be viable when adequate time is available for plants to grow and establish.
- ☐ Irrigation source and supply may be limiting or expensive.

Southern Indiana Stormwater Best Management Practices (BMPs) Stormwater Pollution Prevention (SPPs)		SPP-02													
Activity: Geotextiles															
PLANNING CONSIDERATIONS: Design Life: N/A Acreage Needed: N/A Estimated Unit Cost: N/A Monthly Maintenance: Negligible															
		<div style="border: 1px solid black; width: 40px; height: 40px; margin: 0 auto; display: flex; align-items: center; justify-content: center;"> G </div>													
		Target Pollutants													
		<table style="width: 100%; border-collapse: collapse;"> <tr> <td style="text-align: center; width: 33%;">Significant ♦</td> <td style="text-align: center; width: 33%;">Partial ♦</td> <td style="text-align: center; width: 33%;">Low or Unknown ◇</td> </tr> <tr> <td style="text-align: center;">Sediment ♦</td> <td style="text-align: center;">Heavy Metals ◇</td> <td style="text-align: center;">Nutrients ◇</td> </tr> <tr> <td style="text-align: center;">Oil & Grease ◇</td> <td style="text-align: center;">Bacteria & Viruses ◇</td> <td style="text-align: center;">Floatable Materials ◇</td> </tr> <tr> <td></td> <td style="text-align: center;">Oxygen Demanding Substances ◇</td> <td style="text-align: center;">Toxic Materials ◇</td> </tr> <tr> <td></td> <td></td> <td style="text-align: center;">Construction Waste ◇</td> </tr> </table>	Significant ♦	Partial ♦	Low or Unknown ◇	Sediment ♦	Heavy Metals ◇	Nutrients ◇	Oil & Grease ◇	Bacteria & Viruses ◇	Floatable Materials ◇		Oxygen Demanding Substances ◇	Toxic Materials ◇	
Significant ♦	Partial ♦	Low or Unknown ◇													
Sediment ♦	Heavy Metals ◇	Nutrients ◇													
Oil & Grease ◇	Bacteria & Viruses ◇	Floatable Materials ◇													
	Oxygen Demanding Substances ◇	Toxic Materials ◇													
		Construction Waste ◇													
Description	<p>Geotextiles are used to prevent or reduce the discharge of pollutants to the storm drain system or to watercourses for sloped areas that would otherwise be unstable or have high erosion potential. Geotextiles stabilize soil to utilize rolled and bound fiber material to intercept runoff, reduce its flow velocity, release the runoff as sheet flow, and provide some sediment removal from runoff.</p>														
Suitable Applications	<p>Slopes where soils must be stabilized. Site conditions that may warrant use of geotextile blankets and mats include:</p> <ul style="list-style-type: none"> Step slopes, general steeper than 3:1 (H:V). Slopes where erosion hazard is high. Critical slopes adjacent to sensitive areas, such as streams, wetlands, or other highly valued resources needing protection. Channels with flows exceeding 2 ft/s (0.6 m/s) to 4 ft/s (1.2 m/s). Channels intended to be vegetated and where the design flow exceeds the permissible velocity. The allowable velocity for turf reinforcement mats after vegetative establishment is up to 10 ft/s. Check with the mat manufacturer for allowable velocities. <p style="text-align: center;">Appropriate mat and/or blanket materials must be selected for the specific site application.</p>														
															

Activity: Geotextiles	SPP-02
Installation Procedures	<p>These systems should be designed by a licensed professional civil engineer.</p> <p>Refer to EPP-10: Geotextiles for discussion of material selection, site preparation, seeding, anchoring, installation on slopes, installation in channels, soil filling, and fiber roles. Figures SPP-02-1 through 3 has also been provided to aid in evaluating geotextiles in permanent applications.</p> <p>Applying geotextiles permanently is most often done in support of permanent vegetation, upland and in-channel slope stabilization and erosion prevention. They are also often applied in construction of sediment traps, basins or dry/wet detention ponds outlets or emergency overflow structures.</p>
Maintenance	<p>In the long-term, regular inspection and maintenance is critical to guarantee the geotextile effectiveness.</p> <p>All blankets and mats should be inspected periodically after installation.</p> <p>Depending on the sensitivity of the protected area, inspections should be performed quarterly or biannually to ensure that any soil settlement or other unforeseen factors have not affected the geotextile fabric or fasteners. Thereafter inspections may be reduced to annually or biennially (every two years).</p> <p>Protected areas should be inspected after significant rain storms to check for erosion and undermining. Any failures should be repaired immediately, including replacement of fasteners.</p> <p>If washout or breakages occur, re-install the material after repairing the damage to the slope or channel.</p> <p>Inspect fiber rolls biannually (twice a year), preferably in late fall and early spring. Perform required maintenance including repair or replacement of split, torn, unraveling, or slumping fiber rolls.</p> <p>Geotextiles should also be inspected after extremely long or intensive storm events such as 10-year or less frequent storm events.</p>
Inspection Checklist	<p>q Blankets and mats are typically more expensive than other erosion control measures, primarily due to labor costs. This usually limits their application to areas inaccessible to hydraulic equipment, or where other measures are not applicable, such as channels. Blankets and mats are generally not suitable for excessively rocky sites or areas where the final vegetation will be mowed (since staples and netting can catch in mowers).</p>

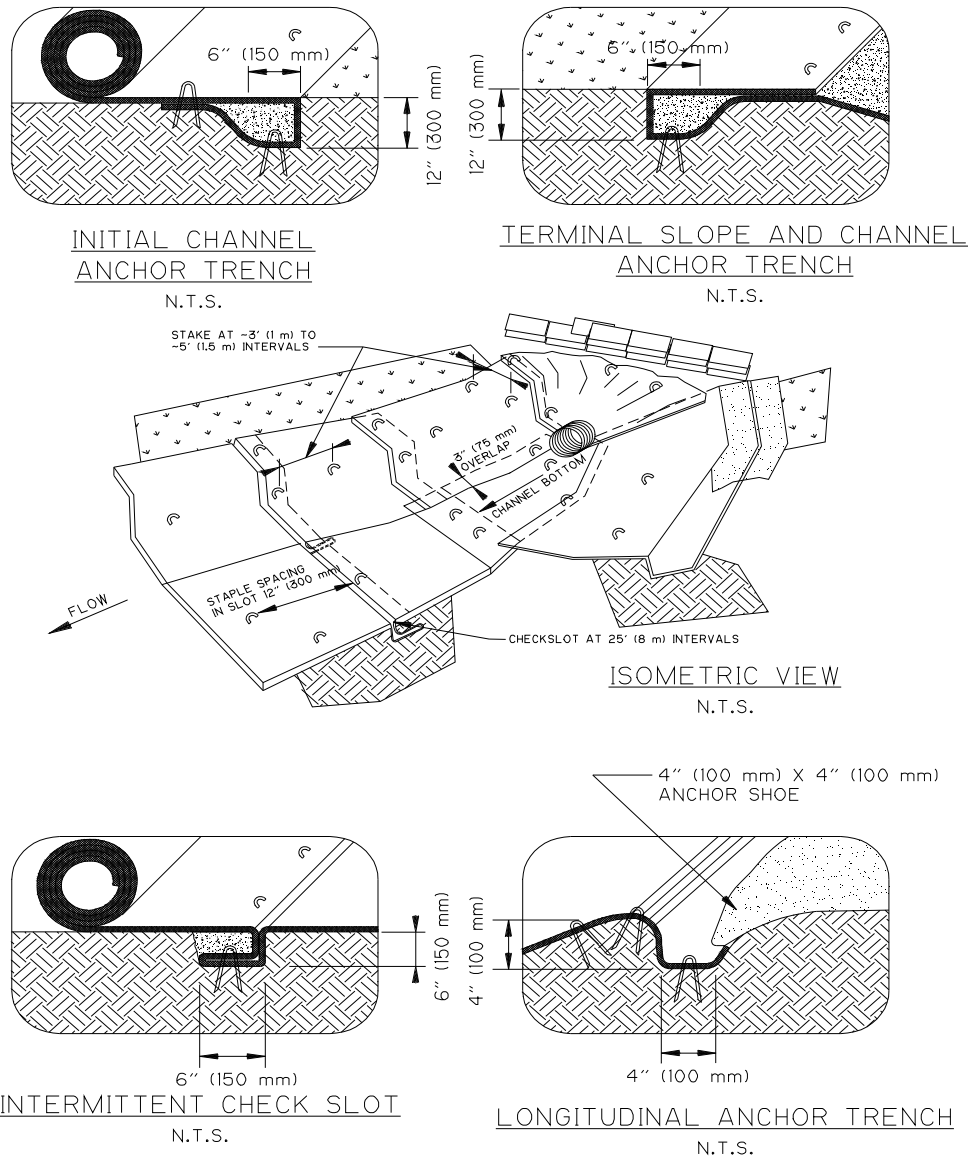

- NOTES:
1. CHECK SLOTS TO BE CONSTRUCTED PER MANUFACTURER'S SPECIFICATIONS.
 2. STAKING OR STAPLING LAYOUT PER MANUFACTURER'S SPECIFICATIONS.

Figure SPP-02-1
Anchoring Geotextiles in Channels

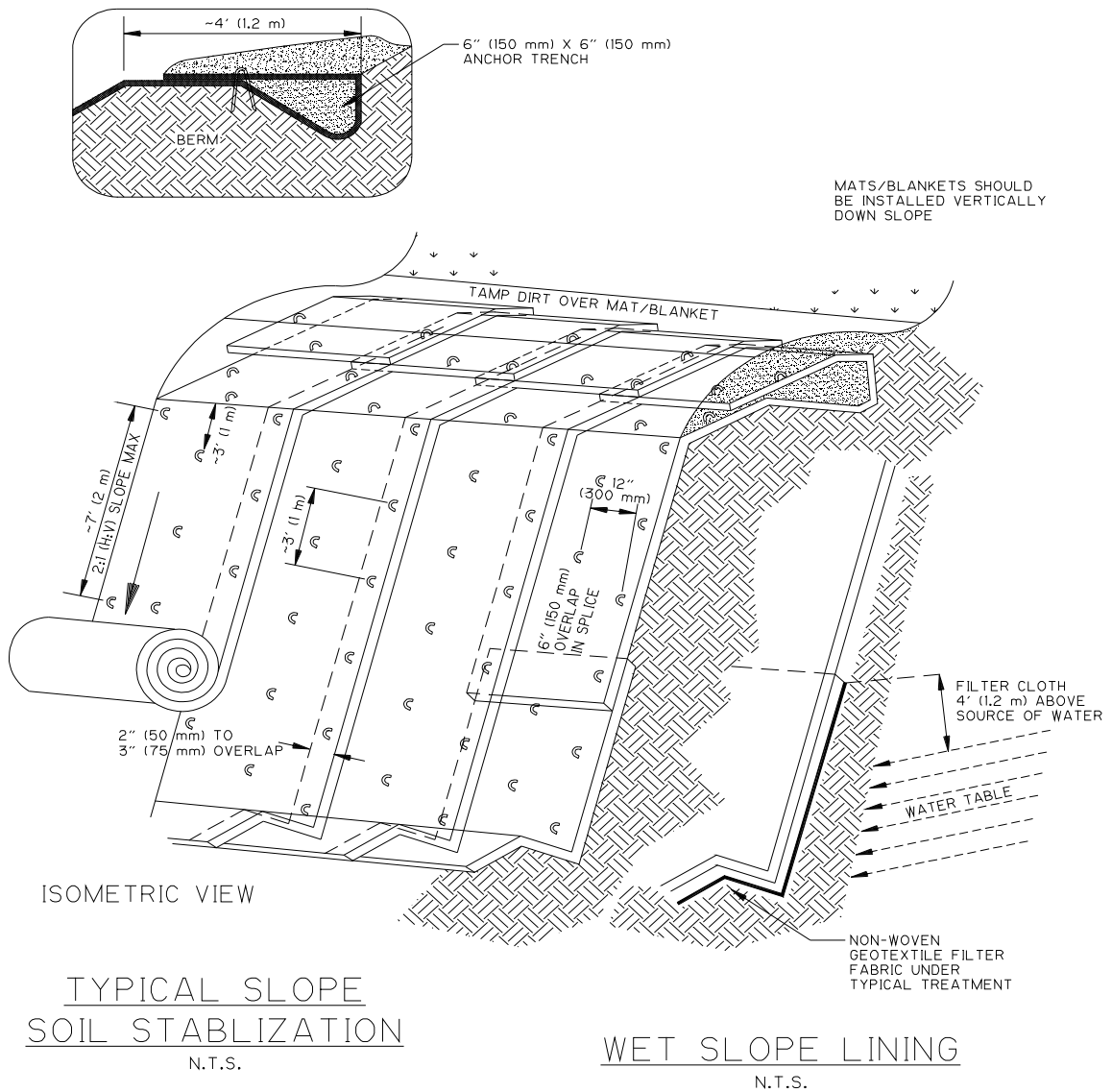

NOTES:

1. SLOPE SURFACE SHALL BE FREE OF ROCKS, SOIL CLODS, STICKS AND GRASS. MATS/BLANKETS SHALL HAVE GOOD SOIL CONTACT.
2. LAY BLANKETS LOOSELY AND STAKE OR STAPLE TO MAINTAIN DIRECT CONTACT WITH THE SOIL. DO NOT STRETCH.

Figure SPP-02-2
Anchoring Geotextiles on Embankments

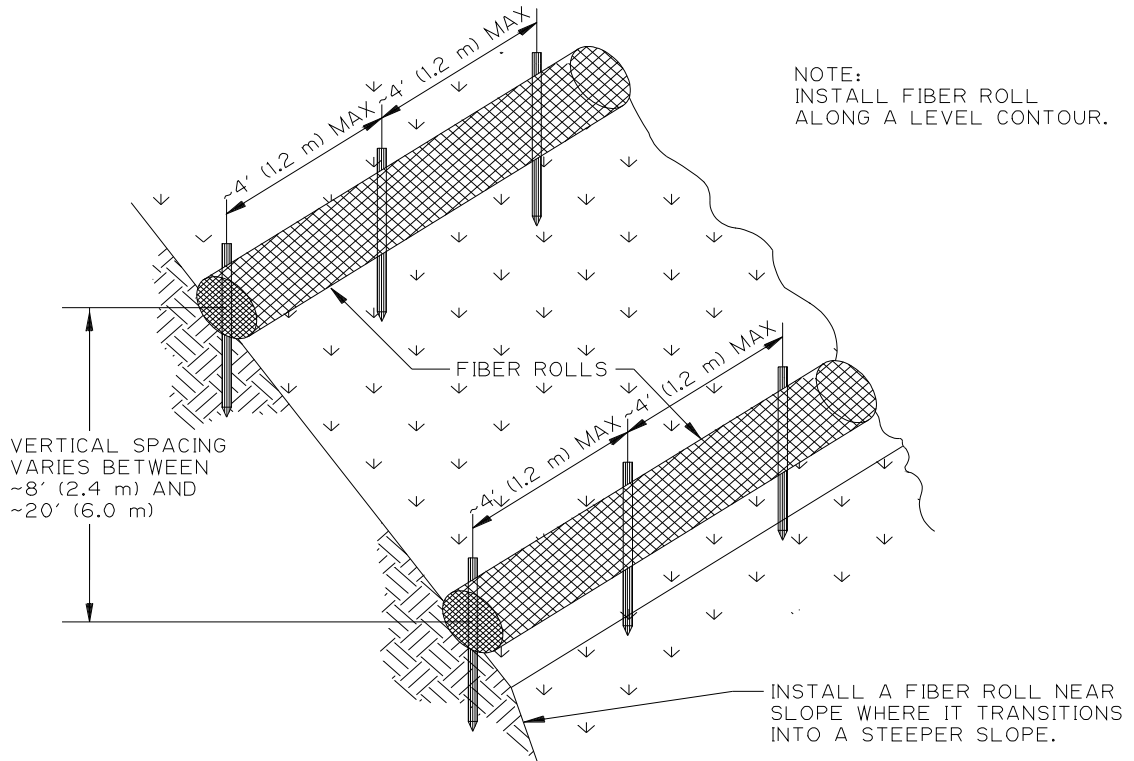

TYPICAL FIBER ROLL INSTALLATION

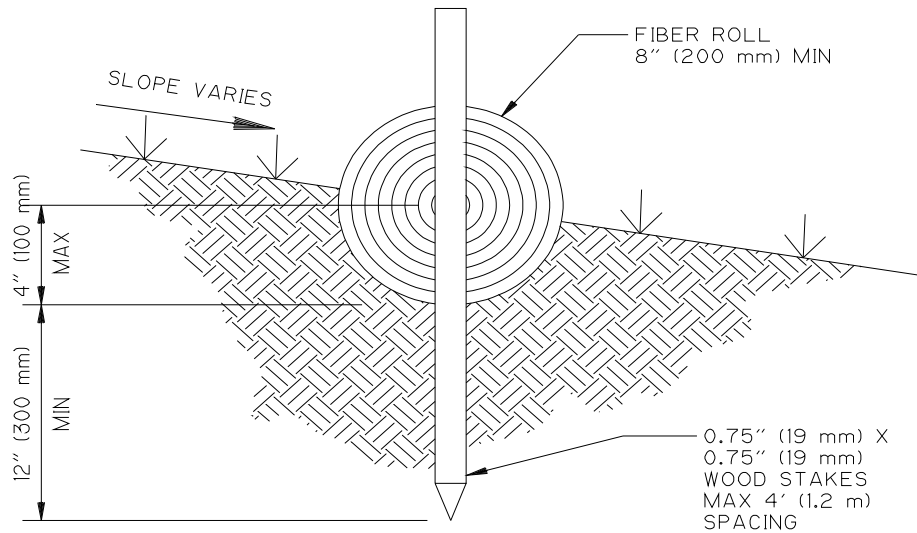

N.T.S.





ENTRENCHMENT DETAIL

N.T.S.

Figure SPP-02-3
Fiber Rolls

<p align="center">Southern Indiana Stormwater Best Management Practices (BMPs) Stormwater Pollution Prevention (SPPs)</p>		<p>SPP-03</p>
<p>Activity: Buffer Zones</p>		
<p>PLANNING CONSIDERATIONS:</p> <p>Design Life: Life</p> <p>Acreage Needed: N/A</p> <p>Estimated Unit Cost: N/A</p> <p>Monthly Maintenance: Negligible</p>		<p>■ PV ■</p>
	<p>Target Pollutants</p>	<p>□ PV □</p>
	<p>Significant ♦ Partial ♦ Low or Unknown ◇</p>	
	<p>Sediment ♦ Heavy Metals ♦ Nutrients ♦ Oxygen Demanding Substances ♦ Toxic Materials ♦ Oil & Grease ♦ Bacteria & Viruses ♦ Floatable Materials ♦ Construction Waste ♦</p>	
<p>Description</p>	<p>Buffer Zones act as shields against pollutants to the drain system or to watercourses by reducing or preventing discharge through vegetation utilization. The utilization protects soils from erosion and slows the velocity of runoff to allow the removal of sediment and other pollutants through filtering and settling.</p>	
<p>Suitable Applications</p>	<p>Buffer zones are effective along stream banks, grassed dikes, swales, slopes, outlets, level spreaders, and filter strips.</p> <p>Vegetative buffer strips may be used on any site that will support vegetation.</p> <p>Buffer strips are particularly effective on flood plains, adjacent to wetlands or other sensitive water bodies, and on steep, unstable slopes.</p> <p>Any area within a buffer required by the local regulations <u>SHALL NOT BE CLEARED</u>. They should be surveyed, flagged, and delineated by a colored temporary construction fence. This should be explained to all construction employees and supervisors.</p> <p>Utilization or reinforcement of existing vegetation is preferred. However, where improvements are required; sodding, plugging, use of stockpiled vegetation or seeding is acceptable.</p>	
		

Activity: Buffer Zones	SPP-03
Suitable Applications (Continued)	<p>Sodding is appropriate if it is part of the no construction activity area required by MDPW for areas that contained turf prior to construction, or for any graded or cleared area that might erode and where a robust plant cover is needed immediately. Examples of locations where sodding may be used include stream banks, grassed dikes, swales, steep slopes, outlets, and level spreaders. Sod along edge of buffer for at least two rows (offset).</p> <p>Plugging is appropriate for the same areas as sodding, except that a longer establishment period before protection is provided as required. Plugging stabilizes an area by planting clumps of grass material, which then grow and spread to provide complete covers. Plugging is generally used for hybrid grasses that cannot be established from seed.</p> <p>Vegetative buffer strips may be used at any location on-site that will support vegetation stockpiled from other areas of the site or from seed. Buffer strips are particularly effective on flood plains, adjacent to wetlands or other sensitive water bodies, and on steep, unstable slopes.</p>
Installation Procedures	<p>These systems should be designed by a licensed professional civil engineer.</p> <p>Many of the measures presented in EPP-04: Buffer Zones and SMP-12: Filter Strips are applicable for establishing and maintaining permanent buffer zones.</p>
Maintenance	<p>Inspect buffer zones monthly for the first year after construction and annually thereafter.</p> <p>Maintenance shall consist of mowing, weeding, and ensuring that the irrigation system is operating properly and as designed to sustain growth.</p> <p>Inspect buffer strips after significant storm events (10-year storm event or larger). Repair eroded or damaged areas as needed to maintain original purpose and effectiveness of the buffer strip.</p>
Inspection Checklist	<p>□ Site conditions will dictate need and design of vegetative buffer strips. Vegetative buffer strips are most economical when there is existing vegetation that can be retained to serve as the buffer strip; otherwise, vegetation will need to be established.</p>

<p>Southern Indiana Stormwater Best Management Practices (BMPs) Stormwater Pollution Prevention (SPPs)</p>		<p>SPP-04</p>															
<p>Activity: Soil Bioengineering and Bank Stabilization</p>																	
<p>PLANNING CONSIDERATIONS:</p> <p>Design Life: N/A</p> <p>Acreage Needed: N/A</p> <p>Estimated Unit Cost: N/A</p> <p>Monthly Maintenance: Negligible</p>		<p>■ BS ■</p>															
		<p>○ BS ○</p>															
	<p>Target Pollutants</p>																
	<table border="1"> <tr> <td>Significant ♦</td> <td>Partial ♦</td> <td>Low or Unknown ◇</td> </tr> <tr> <td>Sediment ♦</td> <td>Heavy Metals ◇</td> <td>Nutrients ◇</td> </tr> <tr> <td>Oil & Grease ◇</td> <td>Bacteria & Viruses ◇</td> <td>Floatable Materials ◇</td> </tr> <tr> <td></td> <td>Oxygen Demanding Substances ◇</td> <td>Toxic Materials ◇</td> </tr> <tr> <td></td> <td></td> <td>Construction Waste ◇</td> </tr> </table>			Significant ♦	Partial ♦	Low or Unknown ◇	Sediment ♦	Heavy Metals ◇	Nutrients ◇	Oil & Grease ◇	Bacteria & Viruses ◇	Floatable Materials ◇		Oxygen Demanding Substances ◇	Toxic Materials ◇		
Significant ♦	Partial ♦	Low or Unknown ◇															
Sediment ♦	Heavy Metals ◇	Nutrients ◇															
Oil & Grease ◇	Bacteria & Viruses ◇	Floatable Materials ◇															
	Oxygen Demanding Substances ◇	Toxic Materials ◇															
		Construction Waste ◇															
<p>Description</p>	<p>Sediment reduction or prevention is the result of the occurrence of this BMP. By handling the amount of discharge into storm drain systems or watercourses slope stabilization is provided, protection and erosion reduction through the use of woody vegetative structures alone or in combination with simple retaining structures also takes place. Many of the measures presented in SMP-08 Bank Stabilization are applicable to this BMP fact sheet.</p>																
<p>Suitable Applications</p>	<p>For protection of slopes against surface erosion, shallow mass wasting, cut and fill slope stabilization, earth embankment protection, and small gully repair treatment.</p>																
<p>Installation Procedures</p>	<p>These systems should be designed by a licensed professional civil engineer.</p> <p>Site Considerations</p> <p>Observe surrounding slopes for vegetation density and overall plant health. Also observe the directions they are facing (some plantings generally do better in eastern exposure and do not survive in southern exposure). Plant health is a good indicator of soil moisture and/or soil conditions. These will help indicate the success of your specific bioengineering project.</p> <p>Make geologic observations of the project site noting soil types and their proneness to slide or fail.</p> <p>Retain existing vegetation whenever possible.</p>																
																	

**Installation
Procedures
(Continued)**

Limit removal of vegetation by keeping the cleared area to the smallest practical size, limiting duration of the surface disturbance, and retaining existing woody vegetation for future planting.

Stockpile and protect topsoil removed during clearing.

Protect areas exposed during construction with erosion prevention (EPP) and sediment management practices (SMP).

Construction Techniques and Materials

Grade or terrace to flatten or make a steep undercut or slumping bank less severe.

Make sure the vegetation chosen does not grow in such a way as to damage simple retaining structures in combination bioengineering systems.

Retention backfill is to have sufficient fines and drainage so as to support chosen vegetation.

Bioengineering systems' installation is best accomplished in the late fall at the onset of plant dormancy. Plants that are not dormant are less likely to survive.

Live stake – the insertion of live, rootable vegetative cuttings into the ground.

Appropriate technique for repair of small earth slips and slumps that are frequently wet.

Live stakes shall be ½" to 1 ½" (1.3 to 3.8 cm) in diameter, 2 to 3' (0.63 to 0.94 m) long, with the basal end cut to an angled point for easy insertion. The top should be cut square.

Tamp the live stake into the ground at right angles to the slope. The installation may be started at any point on the slope face.

The live stakes should be installed 2 to 3 ft. (0.63 to 0.94 m) apart using triangular spacing. The density of the installation will range from 2 to 4 stakes per square yard (0.8 m²).

The buds should be oriented up.

Four-fifths of the length of the live stake should be installed into the ground and soil firmly packed around it after installation.

Do not split the stakes during installation. Stakes that split should be removed and replaced.

An iron bar can be used to make a pilot hole in firm soil. Drive the stake into the ground with a dead blow hammer (hammer head filled with shot or sand).

Live fascine-long bundles of branch cuttings bound together into sausage-like structures.

An effective stabilization technique for slopes.

Live materials should be from species that easily root and have long, straight branches.

Activity: Soil Bioengineering and Bank Stabilization**SPP-04****Installation
Procedures
(Continued)**

Cuttings tied together to form live fascine bundles vary in length from 5 to 30 ft. (1.6 to 9.4 m) or longer, depending on site conditions and limitations in handling.

The completed bundles should be 6 to 8 in. (15.2 to 20.3 cm) in diameter, with all of the growing tips oriented in the same direction. Stagger the cuttings in the bundles so that tops are evenly distributed throughout the length of the uniformly sized live fascine.

Live stakes should be 2 ½ ft. (0.8 m) long in cut slopes and 3 ft. (0.94 m) long in fill slopes.

Dead stout stakes used to secure the live fascines should be 2 ½-foot (0.8 m) long, untreated, 2 by 4 (5.1 by 10.2 cm) lumber. Each length should be cut diagonally across the 4 in. (10.2-cm) face to make two stakes from each length.

Prepare the live fascine bundles and live stakes immediately before installation.

Beginning at the base of the slope, dig a trench on the contour just large enough to contain the live fascine. The trench will vary in width from 12 to 18 in. (30.5 to 45.7 cm), depending on the angle of the slope to be treated. The depth will be 6 to 8 in. (15.2 to 20.3 cm), depending on the individual bundle's final size.

Place the live fascine into the trench.

Drive the dead stout stakes directly through the live fascine every 2 to 3 ft. (0.63 to 0.94 m) to along its length. Extra stakes should be used at connections or bundle overlaps. Leave the top of the stakes flush with the installed bundle.

Live stakes are generally installed on the down slope side of the bundle. Drive the live stakes below and against the bundle between the previously installed dead stout stakes. The live stakes should protrude 2 to 3 in. (5.1 to 7.6 cm) above the top of the live fascine. Place moist soil along the sides of the live fascine. The top of the fascine should be slightly visible when the installation is completed.

Next, at intervals on contour or at an angle up the face of the bank, repeat the preceding steps to the top of the slope (Table SPP-04-1).

Long straw or similar mulching material should be placed between rows on 2.5:1 (H: V) or flatter slopes, while slopes steeper than 2.5:1 (H: V) should have jute mesh or similar material placed in addition to the mulch.

Installation Procedures (Continued)

**Table SPP-04-1
Live Fascine Installation Guidelines**

Slope (H:V)	Slope distance Between trenches (ft)	Maximum slope length (ft)
1:1 to 1.5:1	3 - 4 (0.94 – 1.26 m)	15 (4.7 m)
1.5:1 to 2:1	4 - 5 (1.26 – 1.57 m)	20 (6.3 m)
2:1 to 2.5:1	5 - 6 (1.57 – 1.89 m)	30 (9.4 m)
2.5:1 to 3:1	6 - 8 (1.89 – 2.51 m)	40 (12.6 m)
3.5:1 to 4:1	8 - 9 (2.51 – 2.83 m)	50 (15.7 m)
4.5:1 to 5:1	9 - 10 (2.83 – 3.14 m)	60 (18.9 m)

Bushlayering - similar to live fascine systems, however, in brushlayering the cuttings are oriented more or less perpendicular to the slope contour. Branch cuttings should be ½ to 2 in. (1.3 to 5.1 cm) in diameter and long enough to reach the back of the bench. Side branches should remain intact for installation.

Starting at the toe of the slope, benches should be excavated horizontally, on the contour, or angled slightly down the slope, if needed to aid drainage. The bench should be constructed 2 to 3 ft. (0.63 to 0.94 m) wide.

The surface of the bench should be sloped so that the outside edge is higher than the inside.

Live branch cuttings should be placed on the bench in a crisscross or overlapping configuration.

Branch growing tips should be aligned toward the outside of the bench.

Backfill is placed on top of the branches and compacted to eliminate air spaces.

The brush tips should extend slightly beyond the fill to filter sediment.

Each lower bench is backfilled with the soil obtained from excavating the bench above.

Long straw or similar mulching material with seeding should be placed between rows on 3:1 (H: V) or flatter slopes, while slopes steeper than 3:1 (H: V) should have jute mesh or similar material placed in addition to the mulch.

The brushlayer rows should vary from 3 to 5 ft. (0.94 to 1.57 m) apart, depending upon the slope angle and stability (Table SPP-04-2).

**Table SPP-04-2
Brushlayer Installation Guidelines**

Slope (H:V)	Slope distance between benches		Maximum slope length (ft)
	Wet slopes (ft)	Dry slopes (ft)	
2:1 to 2.5:1	3 (0.94 m)	3 (0.94 m)	15 (4.7 m)
2.5:1 to 3:1	3 (0.94 m)	4 (1.26 m)	15 (4.7 m)
3.5:1 to 4:1	4 (1.26 m)	5 (1.57 m)	20 (6.3 m)

Activity: Soil Bioengineering and Bank Stabilization**SPP-04****Installation
Procedures
(Continued)**

Branchpacking – consists of alternating layers of live branch cuttings and compacted backfill to repair small localized slumps and holes in slopes.

Live branch cuttings may range from ½ in. to 2 in. (1.3 to 5.1 cm) in diameter.

They should be long enough to touch the undisturbed soil at the back of the trench and extend slightly from the rebuilt slope face.

Wooden stakes should be 5 to 8 ft. (1.57 to 2.51 m) long and made from 3- to 4-inch (7.6 to 10.2 cm) diameter poles or 2 by 4 (5.1 by 10.2 cm) lumber, depending upon the depth of the particular slump or hole.

Starting at the lowest point, drive the wooden stakes vertically 3 to 4 ft. (0.94 to 1.26 m) into the ground. Set them 1 to 1 ½ ft. (0.31 to 0.47 m) apart.

A layer of living branches 4 to 6 in. (10.2 to 15.2 cm) thick is placed in the bottom of the hole, between the vertical stakes, and perpendicular to the slope face.

They should be placed in a crisscross configuration with the growing tips generally oriented toward the slope face. Some of the basal ends of the branches should touch the back of the hole or slope.

Subsequent layers of branches are installed with the basal ends lower than the growing tips of the branches.

Each layer of branches must be followed by a layer of compacted soil to ensure soil contact with the branch cuttings.

The final installation should match the existing slope. Branches should protrude only slightly from the filled face.

The soil should be moist or moistened to insure that live branches do not dry out.

Branchpacking is not effective in slump areas greater than 4 or 5 feet (1.26 to 1.57 m) wide.

Live gully repair – utilizes alternating layers of live branch cuttings and compacted soil to repair small rills and gullies.

Limited to rills or gullies which are a maximum of 2 ft. (0.63 m) wide, 1 foot deep (0.31 m), and 15 ft. (4.71 m) long.

Live branch cuttings may range from ½ in. to 2 inches (1.3 to 5.1 cm) in diameter.

They should be long enough to touch the undisturbed soil at the back of the rill or gully and extend slightly from the rebuilt slope face.

Starting at the lowest point of the slope, place a 3- to 4-in. (7.6- to 10.2-cm) layer of branches at lowest end of the rill or gully and perpendicular to the slope.

Cover with a 6- to 8- in. (15.2 to 20.3 cm) layer of fill soil.

Install the live branches in a crisscross fashion. Orient the growing tips toward the slope face with basal ends lower than the growing tips.

Follow each layer of branches with a layer of compacted soil to ensure soil contact with the live branch cuttings.

Live cribwall – a hollow, box-like interlocking arrangement of untreated log or timber members. The structure is filled with suitable backfill material and layers of live branch cuttings which root inside the crib structure and extend into the slope.

**Installation
Procedures
(Continued)**

This technique is appropriate at the base of a slope where a low wall may be required to stabilize the toe.

Live branch cuttings should be ½ to 2 inches (1.3 to 5.1 cm) in diameter and long enough to reach the back of the wooden crib structure.

Logs, timbers or reinforced concrete beams should range from 4 to 6 inches (10.2 to 15.2 cm) in diameter or dimension. The lengths will vary with the size of the crib structure.

Large nails or rebar are required to secure the logs or timbers together.

Starting at the lowest point of the slope, excavate loose material 2 to 3 feet (0.63 to 0.94 m) below the ground elevation until a stable foundation is reached.

Excavate the back of the stable foundation (closest to the slope) slightly deeper than the front to add stability to the structure.

Place the first course of logs, timbers or reinforced concrete beams at the front and back of the excavated foundation, approximately 4 to 5 feet (1.26 to 1.57 m) apart and parallel to the slope contour.

Place the next course of logs or timbers at right angles (perpendicular to the slope) on top of the previous course to overhang the front and back of the previous course by 3 to 6 inches (7.6 to 15.2 cm).

Each course of the live cribwalls is placed in the same manner and nailed to the preceding course with nails or reinforcement bars.

When the cribwall structure reaches the existing ground elevation, place live branch cuttings on the backfill perpendicular to the slope; then cover the cuttings with backfill and compact.

Live branch cuttings should be placed at each course to the top of the cribwall structure with growing tips oriented toward the slope face. Follow each layer of branches with a layer of compacted soil to ensure soil contact with the live branch cuttings. Some of the basal ends of the live branch cuttings should reach to undisturbed soil at the back of the cribwall with growing tips protruding slightly beyond the front of the cribwall.

Vegetated gabions – Vegetated gabions begin as rectangular containers fabricated from a triple twisted, hexagonal mesh of heavily galvanized steel wire. Empty gabions are placed in position, wired to adjoining gabions, filled with stones and then folded shut and wired at the ends and sides. Live branches are placed on each consecutive layer between the rock-filled baskets. These will take root inside the gabion baskets and in the soil behind the structures. In time the roots consolidate the structure and bind it to the slope.

Vegetated rock wall – a combination of rock and live branch cuttings used to stabilize and protect the toe of steep slopes.

Live cuttings should have a diameter of ½ to 1 inch (1.3 to 2.5 cm) and be long enough to reach beyond the rock structure into the fill or undisturbed soil behind. Inert materials consist of rocks and fill material for the wall construction. Rock used should normally range from 8 to 24 inches (20.3 to 61 cm) in diameter. Larger boulders should be used for the base.

Activity: Soil Bioengineering and Bank Stabilization**SPP-04****Installation
Procedures
(Continued)**

Starting at the lowest point of the slope, remove loose soil until a stable base is reached. This usually occurs 2 to 3 feet (0.63 to 0.94 m) below ground elevation. Excavate the back of the stable foundation (closest to the slope) slightly deeper than the front to add stability to the structure.

Excavate the minimum amount from the existing slope to provide a suitable recess for the wall.

Provide a well-drained base in locations subject to deep frost penetration.

Place rocks with at least a three-point bearing on the foundation material or underlying rock course. They should also be placed so that their center of gravity is as low as possible, with their long axis slanting inward toward the slope if possible. When a rock wall is constructed adjacent to an impervious surface, place a drainage system at the back of the foundation and outside toe of the wall to provide an appropriate drainage outlet.

Overall height of the rock wall, including the footing, should not exceed 5 feet (1.57 m).

A wall can be constructed with a sloping bench behind it to provide a base on which live branch cuttings can be placed during construction. Live branch cuttings should also be tamped or placed into the openings of the rock wall during or after construction. The butt ends of the branches should extend into the backfill or undisturbed soil behind the wall.

The live branch cuttings should be oriented perpendicular to the slope contour with growing tips protruding slightly from the finished rock wall face.

Joint planting – involves tamping live cuttings of rootable plant material into soil between the joints or open spaces in rocks that have previously been placed on a slope.

Roots improve drainage by removing soil drainage.

Effective with existing rip-rap structures.

The cuttings must have side branches removed and bark intact. They should range in diameter from ½ to 1 ½ inches (1.3 to 3.8 cm) and be sufficiently long to extend into soil below the rock surface.

Tamp live branch cuttings into the openings of the rock during or after construction. The butt ends of the branches should extend into the backfill or undisturbed soil behind the rip-rap.

Orient the live branch cuttings perpendicular to the slope with growing tips protruding slightly from the finished face of the rock.

Activity: Soil Bioengineering and Bank Stabilization**SPP-04****Maintenance**

During the establishment period, inspect cuttings daily removing any dead stock and replacing it with fresh stock.

Inspect biweekly for the first 2 months. Inspections should note insect infestations, soil moisture, and other conditions that could lead to poor survivability. Immediate action, such as the application of supplemental water, should be taken if conditions warrant.

Inspect monthly for the next 6 months. Systems not in acceptable growing condition should be noted and, as soon as seasonal conditions permit, should be removed from the site and replaced with materials of the same species and sizes as originally specified.

Needed reestablishment work should be performed every 6 months during the initial 2-year establishment period. This will usually consist of replacing dead material.

Extra inspections should always be made during periods of drought or heavy rains. Damaged sections should always be repaired immediately.

Final inspection – A final inspection should be held 2 years after installation is completed. Healthy growing conditions should exist.





Healthy growing conditions in all areas refer to overall leaf development and rooted stems defined as follows:

- Live stakes ----- 70%-100% growing
- Live fascines ----- 20%-50% growing
- Live cribwall ----- 30%-60% growing
- Brushlayers ----- 40%-70% growing
- Branchpacking ----- 40%-70% growing
- Live gully repair ----- 30%-50% growing
- Vegetated rock wall ----- 50%-80% growing
- Vegetated gabion ----- 40%-60% growing
- Joint planting ----- 50%-70% growing

Growth should be continuous with no open spaces greater than 2 feet in linear systems. Spaces 2 feet (0.63 m) or less will fill in without hampering the integrity of the installed living system.

Inspection Checklist

- ☐ Where labor is either scarce or extremely expensive, the cost of soil bioengineering systems may be higher than traditional structural measures. However, it should be noted that soil-bioengineering techniques generally are less expensive.
- ☐ Constraints on planting times or the availability of the required quantities of suitable plant materials during allowable planting times may limit soil bioengineering methods.
- ☐ Rapid vegetative establishment may be difficult on extremely steep slopes.
- ☐ Rocky or gravelly slopes can lack sufficient fines or moisture for plant growth.

Southern Indiana Stormwater Best Management Practices (BMPs) Stormwater Pollution Prevention (SPPs)		SPP-05														
Activity: Gradient Terraces and Slope Roughening																
PLANNING CONSIDERATIONS: Design Life: Life Acreage Needed: N/A Estimated Unit Cost: N/A Monthly Maintenance: Negligible																
																
	Target Pollutants															
	<table border="0"> <tr> <td style="text-align: center;">Significant ♦</td> <td style="text-align: center;">Partial ♦</td> <td style="text-align: center;">Low or Unknown ◇</td> </tr> <tr> <td style="text-align: center;">Sediment ♦</td> <td style="text-align: center;">Heavy Metals ◇</td> <td style="text-align: center;">Nutrients ◇</td> </tr> <tr> <td style="text-align: center;">Oil & Grease ◇</td> <td style="text-align: center;">Bacteria & Viruses ◇</td> <td style="text-align: center;">Floatable Materials ◇</td> </tr> <tr> <td style="text-align: center;"></td> <td style="text-align: center;">Oxygen Demanding Substances ◇</td> <td style="text-align: center;">Toxic Materials ◇</td> </tr> <tr> <td style="text-align: center;"></td> <td style="text-align: center;">Construction Waste ◇</td> <td style="text-align: center;"></td> </tr> </table>		Significant ♦	Partial ♦	Low or Unknown ◇	Sediment ♦	Heavy Metals ◇	Nutrients ◇	Oil & Grease ◇	Bacteria & Viruses ◇	Floatable Materials ◇		Oxygen Demanding Substances ◇	Toxic Materials ◇		Construction Waste ◇
Significant ♦	Partial ♦	Low or Unknown ◇														
Sediment ♦	Heavy Metals ◇	Nutrients ◇														
Oil & Grease ◇	Bacteria & Viruses ◇	Floatable Materials ◇														
	Oxygen Demanding Substances ◇	Toxic Materials ◇														
	Construction Waste ◇															
Description	Prevent or reduce the discharge of pollutants to the storm drain system or to watercourses as a result of construction activity by terracing slopes to reduce erosion by decreasing runoff velocities, tapping sediment, increasing infiltration, and aiding in supporting vegetative cover.															
Suitable Applications	Slopes steeper than 3:1 (H:V) and greater than 5 ft. in height Graded areas with smooth hard surfaces Where length of slopes needs to be sirtened by terracing. Note: terracing is usually permanent, and should be designed under the direction of and approved by a licensed professional civil engineer based in site conditions. Terraces must be designed with adequate drainage and stabilized outlets.															
Installation Procedures	These systems should be designed by a licensed professional civil engineer. Terracing installation techniques are presented in EPP-11: Terracing. Refer the BMP to review Technical Figures. In the event that terraced slopes become unstable or flow is diverted to them to an extent that the practice becomes ineffective in limiting erosion or stabilizing vegetation, then alternative measures should be considered. Alternative measures can include flow diversion, drains, swales, level spreaders, geotextiles and bank stabilization practices described in the EPP section. These measures should be designed to consider the permanent structure/slope and other site conditions.															
																



Activity: Gradient Terraces and Slope Roughening**SPP-05****Maintenance**

Periodically check the seeded or planted slopes for rills and washes, particularly after significant storm events greater than 0.5 in. (12 mm). Fill these areas slightly above the original grade, then reseed and mulch as soon as possible.

Inspect monthly for the first year after construction. The slope should be inspected in early fall thereafter.

Inspection Checklist

- Stair-step grading may not be practical for sandy, steep, or shallow soils.

Southern Indiana Stormwater Best Management Practices (BMPs) Stormwater Pollution Prevention (SPPs)		SPP-06	
Activity: Flow Diversion, Drains and Swales			
PLANNING CONSIDERATIONS: Design Life: Life Acreage Needed: N/A Estimated Unit Cost: N/A Monthly Maintenance: Negligible		PS	
		PS	
		Target Pollutants	
		Significant ♦ Partial ♦ Low or Unknown ◇ Sediment ♦ Heavy Metals ◇ Nutrients ◇ Oxygen Demanding Substances ◇ Toxic Materials ◇ Oil & Grease ◇ Bacteria & Viruses ◇ Floatable Materials ◇ Construction Waste ◇	
Description	Permanent drains and swales are used to divert runoff from stabilized areas around disturbed areas, and direct runoff into sediment basins or detention ponds.		
Suitable Applications	The primary function of a slope drain is to convey runoff down cut or fill slopes. The primary function of a subsurface drain is to drain excessive soil saturation in sloping areas. The primary function of top and toe of slope diversion swales, ditches, and berms is to minimize sheet flow over slope surfaces and reduce sedimentation by conveying collected runoff to a protected drainage system. These management practices are likely to create a significant reduction in sediment.		
Installation Procedures	These systems should be designed by a licensed professional civil engineer. Installation/Application criteria for permanent flow diversions, drains and swales are presented in SMP-11: Temporary Diversions, Drains and Swales. The principal differences between temporary and permanent measures of this type are factor of safety over sizing to account for large storm events and less frequent inspections. These practices should be designed by a licensed professional civil engineer.		
Maintenance	Drains should be inspected monthly the first year after construction and annually thereafter. Diversions should be inspected every other month the first year after construction and annually thereafter.		
			

Activity: Flow Diversion, Drains and Swales**SPP-06****Maintenance
(Continued)**

The diversions and drains should be inspected immediately after any storm event equal to or larger than the 10-year storm event.

Inspect outlet for erosion and downstream scour. If eroded, repair damage and install additional energy dissipation measures. If downstream scour is occurring, it may be necessary to reduce flows being discharged into the channel unless other preventative measures are implemented.

Inspect slope drainage for accumulations of debris and sediment.

Remove built-up sediment from entrances and outlets as required. Flush drains if necessary; capture and settle out sediment from discharge.

Inspect ditches/berms for washouts. Replace lost riprap, damaged linings or soil stabilizers as needed.

To avoid creating indentions that could reconcentrate flows, avoid operation of vehicles and heavy equipment in the level spreader. When indentions are formed, grade, fill, and revegetate as needed.

Inspect for debris and sediment accumulation in spreader channel. Remove accumulated debris and sediment as needed. Sediment should be removed from the level spreader if it has reached ½ of sediment storage capacity.

Inspect level spreaders prior to the rainy season and after significant rainfall events.



Inspect level spreader lip to verify a zero percent slope.

Inspect for evidence of erosion below spreader. This could indicate lip is no longer level.

Inspect for evidence of flow reconcentration of spreader discharge.

**Inspection
Checklist**

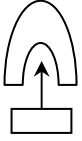
- Subsurface drains may remove fine soils which can result in collapse of the slope. Filter cloth should be used in this case.
- Severe erosion may result if slope drains fail by over topping, soil piping, or pipe separation.
- Maximum flow into the spreader should not exceed 30 cfs (0.85 m³/s).
- Lip of level spreader must have a zero slope for proper operation.
- A level spreader is not a sediment trapping or filtering device, but may accumulate sediment that must be removed.
- Ditches/berms are not sediment trapping devices, but may accumulate sediment that must be removed.

Southern Indiana Stormwater Best Management Practices (BMPs) Stormwater Pollution Prevention (SPPs)		SPP-07													
Activity: Outlet Protection															
PLANNING CONSIDERATIONS: Design Life: Permanent Acreage Needed: Minimal Estimated Unit Cost: Varies Monthly Maintenance: Varies															
		<div style="border: 1px solid black; padding: 5px; display: inline-block;"> TOP </div>													
		Target Pollutants													
		<table style="width: 100%; border-collapse: collapse;"> <tr> <td style="text-align: center; width: 33%;">Significant ♦</td> <td style="text-align: center; width: 33%;">Partial ♦</td> <td style="text-align: center; width: 33%;">Low or Unknown ♦</td> </tr> <tr> <td style="text-align: center;">Sediment ♦</td> <td style="text-align: center;">Heavy Metals ♦</td> <td style="text-align: center;">Nutrients ♦</td> </tr> <tr> <td style="text-align: center;">Oil & Grease ♦</td> <td style="text-align: center;">Bacteria & Viruses ♦</td> <td style="text-align: center;">Floatable Materials ♦</td> </tr> <tr> <td></td> <td style="text-align: center;">Oxygen Demanding Substances ♦</td> <td style="text-align: center;">Toxic Materials ♦</td> </tr> <tr> <td></td> <td style="text-align: center;">Construction Waste ♦</td> <td></td> </tr> </table>	Significant ♦	Partial ♦	Low or Unknown ♦	Sediment ♦	Heavy Metals ♦	Nutrients ♦	Oil & Grease ♦	Bacteria & Viruses ♦	Floatable Materials ♦		Oxygen Demanding Substances ♦	Toxic Materials ♦	
Significant ♦	Partial ♦	Low or Unknown ♦													
Sediment ♦	Heavy Metals ♦	Nutrients ♦													
Oil & Grease ♦	Bacteria & Viruses ♦	Floatable Materials ♦													
	Oxygen Demanding Substances ♦	Toxic Materials ♦													
	Construction Waste ♦														
Description	<p>By utilizing devices placed at outlets to pipes and channels to reduce the velocity and/or energy of exiting water pollutants are reduced or prevented to storm drain systems or to watercourses. This is a means of controlling erosion and scour to the constructed areas.</p>														
Suitable Applications	<p>Outlets of pipes, drains, culverts, conduits or channels. Outlets located at the bottom of mild to steep slopes. Outlets of channels which carry continuous flows of water. Outlets subject to short, intense flows of water, such as flash floods. Where lined conveyances discharge to unlined conveyances.</p>														
Installation Procedures	<p>These systems should be designed by a licensed professional civil engineer. Carefully place rip-rap to avoid damaging the filter fabric. For proper operation of apron: Construct apron at zero grade. Align apron with receiving stream and keep straight throughout its length. If a curve is needed to fit site conditions, place it in upper section of apron. If size of apron rip-rap is 12 in. (300 mm) or larger, protect underlying filter fabric with 4 in. (100 mm) minimum gravel blanket.</p> <p>Outlets at top of cut slopes or on slopes steeper than 10% should have additional protection due to reconcentration and large velocity of flow leaving the structural apron. Temporary devices should be completely removed as soon as the surrounding drainage area has been stabilized, or at the completion of construction. However, temporary devices can serve as permanent devices if properly sized and reinforced with a factor of safety to account for less frequent inspection and maintenance.</p>														
															

Activity: Outlet Protection**SPP-07****Maintenance**

Permanent outlet protection should be inspected monthly through the first year after construction and annually thereafter.



Permanent outlet protection should be inspected after any storm events equal to or larger than a 10-year storm event.

Inspect apron for displacement of the rip-rap and/or damage to the underlying fabric. Repair fabric and replace rip-rap which has washed away.

Inspect for scour beneath the rip-rap and around the outlet. Repair damage to slopes or underlying filter fabric immediately.

Inspection Checklist

- ☐ Large storms can wash away the rock outlet protection and leave the area susceptible to erosion.
- ☐ Sediment captured by the rock outlet protection may be difficult to remove without removing the rock.
- ☐ While reducing flow velocities, outlet protection may negatively impact the channel habit.
- ☐ Grouted rip-rap may break up in areas of freeze and thaw.
- ☐ Grouted rip-rap may break up from hydrostatic pressure without adequate drainage.

Southern Indiana Stormwater Best Management Practices (BMPs) Stormwater Pollution Prevention (SPPs)		SPP-08													
Activity: Channel Lining															
PLANNING CONSIDERATIONS: Design Life: Permanent Acreage Needed: Minimal Estimated Unit Cost: Varies on design and materials Monthly Maintenance: Minimal															
		<div style="border: 1px solid black; width: 40px; height: 40px; margin: 0 auto; display: flex; align-items: center; justify-content: center;"> CL </div>													
		Target Pollutants													
		<table style="width: 100%; border-collapse: collapse;"> <tr> <td style="text-align: center; width: 33%;">Significant ♦</td> <td style="text-align: center; width: 33%;">Partial ♦</td> <td style="text-align: center; width: 33%;">Low or Unknown ◇</td> </tr> <tr> <td style="text-align: center;">Sediment ♦</td> <td style="text-align: center;">Heavy Metals ◇</td> <td style="text-align: center;">Nutrients ◇</td> </tr> <tr> <td style="text-align: center;">Oil & Grease ◇</td> <td style="text-align: center;">Bacteria & Viruses ◇</td> <td style="text-align: center;">Floatable Materials ◇</td> </tr> <tr> <td></td> <td style="text-align: center;">Oxygen Demanding Substances ◇</td> <td style="text-align: center;">Toxic Materials ◇</td> </tr> <tr> <td></td> <td style="text-align: center;">Construction Waste ◇</td> <td></td> </tr> </table>	Significant ♦	Partial ♦	Low or Unknown ◇	Sediment ♦	Heavy Metals ◇	Nutrients ◇	Oil & Grease ◇	Bacteria & Viruses ◇	Floatable Materials ◇		Oxygen Demanding Substances ◇	Toxic Materials ◇	
Significant ♦	Partial ♦	Low or Unknown ◇													
Sediment ♦	Heavy Metals ◇	Nutrients ◇													
Oil & Grease ◇	Bacteria & Viruses ◇	Floatable Materials ◇													
	Oxygen Demanding Substances ◇	Toxic Materials ◇													
	Construction Waste ◇														
Description Suitable Applications Installation Procedures	<p>Channel lining is the artificial surfacing of bed, banks, shore or embankments to resist erosion or scour.</p> <p>Soft (geotextiles) channel lining can be used to support permanent vegetative growth in a drainage way or as protection prior to placement of a permanent protective layer.</p> <p>Permanent (hard or soft) channel lining can be used when an ordinary seeding and mulch application would not be expected to withstand the force of channel flow.</p> <p>Permanent lining can only be applied in dry-weather channels (having flow most the year) with expressed permission from IDEM.</p> <p>These systems should be designed by a licensed professional civil engineer.</p> <p>The following materials are applicable for soft (or “green”) channel linings. Generally, these types of practices are not applied in dry-weather streams (have water flowing most of the year). These practices are most often effective in wet-weather conveyances (only have flow when it rains).</p> <ul style="list-style-type: none"> Excelsior Jute mats and cells Wood fiber mats and cells Geosynthetic mats or cells Brushlayering 														
															

Activity: Channel Lining**SPP-08****Installation Procedures (Continued)**

The following “hard” materials are applicable for permanently lining channels.

- Pre-cast concrete block (“woven” or individually placed)
- Rip rap
- Cast-in-place concrete
- Gabions
- Sacked concrete
- Soil cement
- Air blown mortar

Rip rap, cast-in-place concrete, and pre-cast concrete blocks should only be utilized with expressed permission from the Engineering Department.

Application of the net and matting materials above is described in the Nets and Mats (EPP-09), and Geotextiles (EPP-10) BMPs.

Brushlayering applications are discussed in detail in SMP-05: Brush or Rock Filters and Continuous Berms.

Riprap installation is detailed in SMP-09: Riprap.

Maintenance

Soft (or “green”) channel linings should be inspected monthly for the first year after construction, quarterly through the second year after construction and biannually (twice per year) thereafter.

Hard channel linings should be inspected monthly for the first year after construction and annually thereafter.

If net or matting materials are damaged, repair or replace immediately.

Any spaces left bare in riprap or brushlayering applications due to erosion or scouring are to be repaired and replaced with their respective lining materials.

Inspection Checklist

- ☐ Hard (concrete, rip rap, etc.) permanent channel linings often result in prevention of habitat establishment.
- ☐ Inadequate coverage results in erosion, washout, and poor plant establishment.
- ☐ If the channel grade and liner are not appropriate for the amount of runoff, channel bottom erosion may result.
- ☐ If the channel slope is too steep or riprap is too small, displacement may occur.
- ☐ Riprap may block channel resulting in erosion along the edge.